





	<h1>LUMI 023</h1>			Code / Réf	
				50195 : 3000K	
				50196 : 4000K	
				50198 : 3000K	
50199 : 4000K					

220-240V~ 50/60Hz	19,5W		 0,638 kg						
----------------------	-------	---	--	---	---	---	---	---	---

FR	 Ne jetez pas vos déchets électriques avec les déchets ménagers. Confiez votre appareil à votre centre de recyclage pour son traitement approprié.	 Suivez la fiche d'instructions pour garantir un fonctionnement fiable et sécurisé. À conserver pour consultation ultérieure. Les produits doivent être installés par un électricien qualifié conformément aux normes internationales de câblage.
EN	Waste electrical products must not be disposed of with household waste. This tool should be taken to your recycling center for safe treatment.	Follow Instruction Sheet to ensure safe and reliable operation. Retain for future reference. Products should be installed by a qualified Electrician in accordance with International Wiring Regulations.
DE	Dieses Gerät darf nicht mit dem Hausmüll/Restmüll entsorgt werden. Das Altgerät nur in einer öffentlichen Sammelstelle abgeben.	Die Gebrauchsanweisung befolgen, damit der sichere und zuverlässige Betrieb gewährleistet ist. Zum späteren Nachschlagen aufheben. Die Produkte müssen von einem qualifizierten Elektriker in Übereinstimmung mit den relevanten Vorschriften installiert werden.
IT	I rifiuti elettrici non devono essere smaltiti con i rifiuti domestici. Questo strumento deve essere portato al centro di riciclaggio per un trattamento sicuro.	Seguire il foglio delle istruzioni per garantire il funzionamento sicuro e affidabile. Conservare per riferimento futuro. I prodotti devono essere installati da un elettricista qualificato conformemente alle normative internazionali sui cablaggi.
ES	Los productos eléctricos de desecho no deben ser eliminados con residuos domésticos. Esta herramienta debe ser llevada a su centro de reciclaje para un tratamiento seguro.	Siga la hoja de instrucciones para garantizar la seguridad y un funcionamiento fiable. Consérvela para utilizarla como material de referencia en el futuro. Los productos los debe instalar un técnico electricista cualificado en virtud de las normativas internacionales en materia de cableado.
FR	La source lumineuse (LED) contenue dans ce luminaire n'est pas remplaçable, lorsque la source lumineuse atteint sa fin de vie le luminaire entier doit être remplacé.	<div style="display: flex; align-items: center; justify-content: center;"> <div style="font-size: 2em; margin-right: 10px;">F</div> <div style="display: flex; gap: 10px;">   </div> <div style="margin-left: 20px;">   </div> </div>
EN	The light source (LED) contained in this luminaire is not replaceable, when the light source reaches its end of life the entire luminaire must be replaced.	
DE	Die in dieser Leuchte enthaltene Lichtquelle (LED) ist nicht auswechselbar, wenn die Lichtquelle ihre Lebensdauer erreicht, muss die gesamte Leuchte ersetzt werden.	
IT	La sorgente luminosa (LED) contenuta in questo apparecchio non è sostituibile, quando la sorgente luminosa raggiunge la fine della sua vita l'intero apparecchio deve essere sostituito.	
ES	La fuente luminosa (LED) contenida en esta luminaria no es sustituible, cuando la fuente luminosa llega a su fin de vida útil debe sustituirse toda la luminaria.	
FR	Ce produit contient une source lumineuse de classe d'efficacité énergétique	
EN	This product contains a light source of energy efficiency class	
DE	Dieses Produkt enthält eine Lichtquelle der Energieeffizienzklasse	
IT	Questo prodotto contiene una sorgente luminosa di classe di efficienza energetica	
ES	Este producto contiene una fuente luminosa de la clase de eficiencia energética	

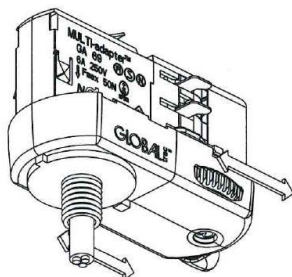
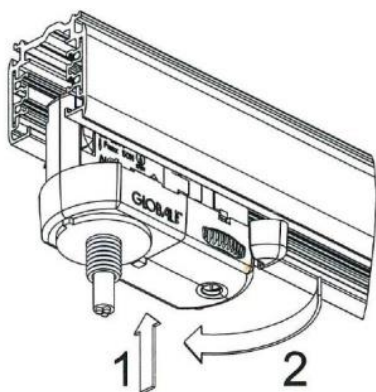

FR	<p>Insérez l'adaptateur dans le rail, afin que la protection anti-torsion de l'adaptateur corresponde à la rainure du rail.</p> <p>Faites pivoter le levier de la came d'environ 90° jusqu'à ce qu'il atteigne la position de verrouillage. Pour l'ouvrir, tournez le levier dans le sens opposé.</p> <p>Lorsque le rail est connecté à un système triphasé, il est possible de sélectionner la phase pour répartir les luminaires individuels dans le système, au moyen du sélecteur approprié de l'adaptateur.</p>
EN	<p>Insert the adapter into the track, that the twist protection of the adaptor matches the groove in the track.</p> <p>Rotate of about 90° the lever of the cam until it reaches the locking position. To open rotate the lever the opposite direction.</p> <p>When the track is connected to a three-phase system, it is possible to select the phase to distribute the single luminaires in the system, by means of the proper selector of the adaptor.</p>
DE	<p>Den Adapter so in die Stromschiene einsetzen, dass der Verdrehenschutz vom Adapter in die Aussparung der Schiene passt.</p> <p>Den Hebel des Drehschließmechanismus um ca. 90° drehen, bis er einrastet. Zum Lösen den Hebel in die entgegengesetzte Richtung drehen.</p> <p>Wenn die Stromschiene an eine Dreiphasen-Anlage angeschlossen ist, kann ausgewählt werden, über welche Phase der einzelne Strahler gespeist wird. Dazu den Wahlschalter vom Adapter entsprechend einstellen.</p>
IT	<p>Inserire l'adattatore nel binario, in modo che la protezione antitorsione di l'adattatore corrisponda alla scanalatura del binario.</p> <p>Ruotare la leva a camma di circa 90° fino a raggiungere la posizione di blocco. Per aprirlo, ruotare la leva nella direzione opposta.</p> <p>Quando il binario è collegato a un sistema trifase, è possibile selezionare la fase di distribuzione dei singoli apparecchi nel sistema, utilizzando l'apposito selettore sull'adattatore.</p>
ES	<p>Inserte el adaptador en el riel de forma que la protección contra la torsión del adaptador coincida con la ranura del riel.</p> <p>Gire aproximadamente 90° la palanca de la leva hasta que alcance la posición de bloqueo. Para abrir, gire la palanca en la dirección opuesta.</p> <p>Cuando el riel está conectado a un sistema trifásico, es posible seleccionar la fase para distribuir las luminarias individuales en el sistema, mediante el selector adecuado del adaptador.</p>